

T95

MINIDUMPER

**CAPACITÀ OPERATIVA
OPERATING WEIGHT**
900 KG · 1984 LBS

**LARGHEZZA AI CINGOLI
TRACK WIDTH**
780 MM · 27.9 INCH

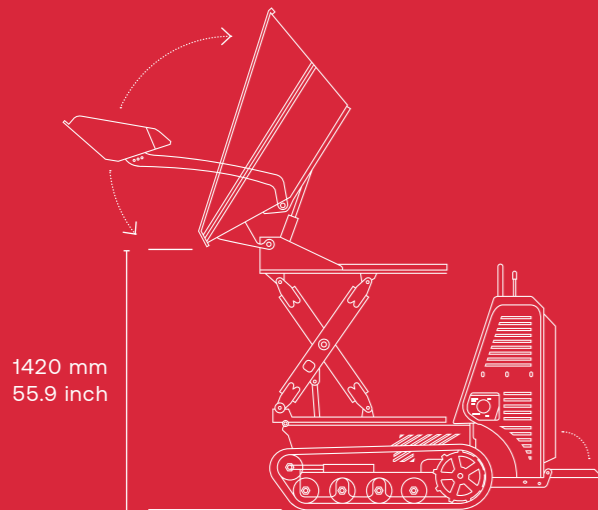
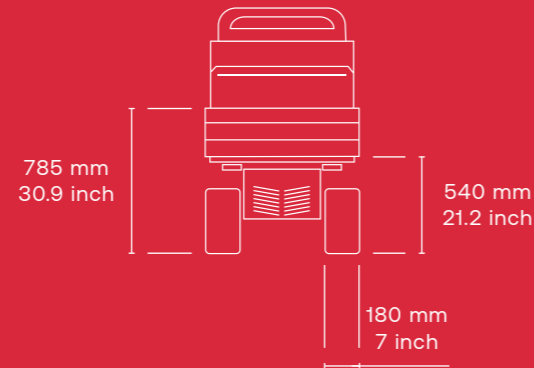
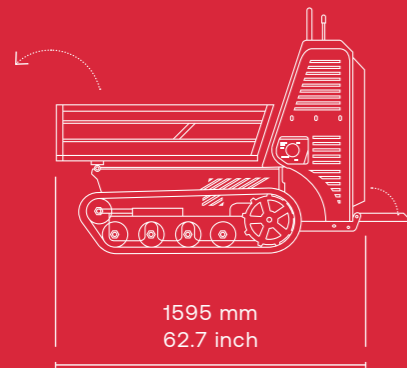
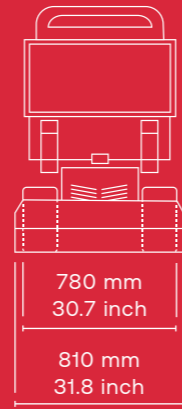
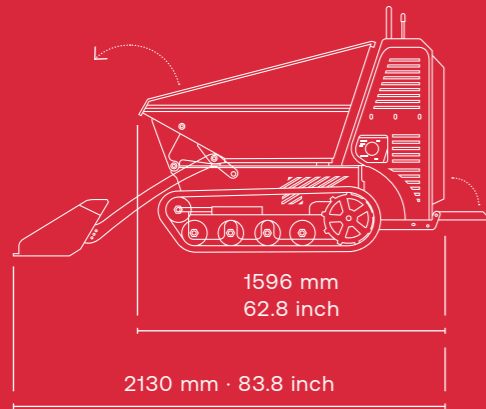

MOTORE TERMICO ENGINE

- HONDA GX390
- YANMAR L100

TRASMISSIONE TRANSMISSION

- IDROSTATICA
- HYDROSTATIC

POMPA IDRAULICA HYDRAULIC PUMP

- 2xPORT. VAR. + 1 POMPA INGR
- 2xVAR. DISPL. + 1 GEAR PUMP

MOTORE IDRAULICO HYDRAULIC MOTOR

- 2 x ORBITALI
- 2 x ORBITAL

PORTATA POMPA PUMP FLOW RATE

- 2X32 L/MIN + 1 POMPA INGR
- 2X8.5 GPM + 1 GEAR PUMP

PRESSIONE MASSIMA MAX PRESSURE

180 bar

RAFFREDDAMENTO IDRAULICO HYDRAULIC COOLING SYSTEM

- ARIA
- AIR

LARGHEZZA CINGOLI TRACK WIDTH

180 mm
7 inch

RULLI TRACK ROLLERS

→ 4

RULLI OSCILLANTI ROCKING ROLLERS

- SI
- YES

REGOLAZIONE CINGOLI TRACK TENSIONER

- SI
- YES

VELOCITÀ DI TRASLAZIONE TRAVEL SPEED

→ 5 KM/H
→ 3.1 MP/H

CAPACITÀ OPERATIVA OPERATING WEIGHT

→ 900 KG / 1984 LBS

HIGH-TIP

→ 800 KG / 1763 LBS

MASSA A VUOTO EMPTY WEIGHT

500 kg
1102 lbs

CONTROLLO CONTROL

→ MONOJOYSTICK

CARATTERISTICHE TECNICHE / TECHNICAL FEATURES

 RASO 0.30 m³
STRUCK 0.39 yd³

 COLMO 0.36 m³
HEAPED 0.45 yd³

 RASO 0.17 m³
STRUCK 0.22 yd³

 COLMO 0.25 m³
HEAPED 0.32 yd³

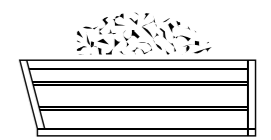
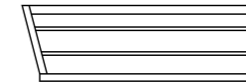
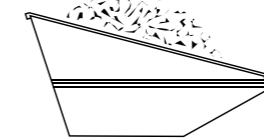
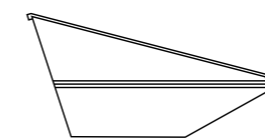

 RASO 0.28 m³
STRUCK 0.37 yd³

 COLMO 0.36 m³
HEAPED 0.47 yd³

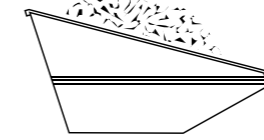
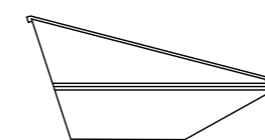

CAPACITÀ / CAPACITY