

### Applications

Forestry

Landscaping

### Main features

Provides you a complete tree and brush management package  
 Cut higher trees and limbs down to size - Grind trees from top to bottom - Produce mulch  
 Spiral tooth pattern allows one tooth to engage at a time for smoother operation and less horsepower demand  
 Double-tipped carbide teeth efficiently rip through hard and soft woods, provide long life

Can operate below grade to process mulch into the soil  
 Pressure gauge is visible from the seat to help operator run the attachment at peak efficiency  
 The standard front gate can reduce front discharge of material and can promote longer processing into finer mulch  
 The Bobcat® Forestry Applications Kit protects the operator and the machine

### Compatibility

Description	Item number	Compatible with loader
FRC150HT	7310677	A770-E, S770-E, T770-E, T870-E, S850-E, S770-E2, T770-E2, A770-E2, S850-E2, T870-E2, S770-B, S850-B, T770-B, T870-B, A770-B
FRC200HT	7307970	A770-E, S770-E, T770-E, T870-E, S850-E, S770-E2, T770-E2, A770-E2, S850-E2, T870-E2, S770-B, S850-B, T770-B, T870-B, A770-B

### Characteristics and performance

Description	Item number	Cutting width (mm)	Number of teeth	Tree diameter, continuous use (mm)	Tree diameter, intermittent use (mm)	Tree diameter, occasional removal (mm)	Working width (mm)	Working depth (up to) (mm)	Bucket capacity (L)	Performance	Working Pressure (bar)	Working Flow (L/min)
FRC150HT	7310677	1500.0	30	100.0-120.0	180.0-220.0	250.0-300.0	-	-	-	-	-	-
FRC200HT	7307970	2000.0	36	100.0-120.0	180.0-220.0	250.0-300.0	-	-	-	-	-	-

### Weights and dimensions

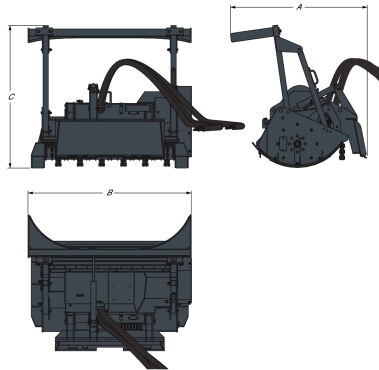

Description	Item number	Operating weight (kg)	Shipping weight (kg)	Overall length (A) (mm)	Overall width (B) (mm)	Overall height (C) (mm)
FRC150HT	7310677	1050.0	1050.0	1219.0	1753.0	1437.0
FRC200HT	7307970	1270.0	1270.0	1219.0	2253.0	1437.0