



Bobcat®

**COMPACT EXCAVATORS
E57W**



One Tough Animal™

E57W— SPECIFICATIONS

WEIGHTS

Operating weight with ROPS cab, tires, standard bucket (SAE J732)	5920 kg
Additional weight for long dipperstick	23 kg

ENGINE

Make / model	Bobcat/D24
Fuel	Diesel
Number of cylinders	4
Displacement	2392 cm ³
Maximum power at 2400 RPM (SAE J1349)	42.5 kW
Maximum net torque at 1800 RPM (SAE J1995)	204.9 Nm

PERFORMANCE

Digging force, standard dipperstick (ISO 6015)	28000 N
Digging force, long dipperstick (ISO 6015)	25000 N
Digging force, bucket (ISO 6015)	42000 N
Drawbar pull	32360 N
Travel speed, low range	10 km/h
Travel speed, high range	30 km/h

HYDRAULIC SYSTEM

Pump type	Two engine-driven piston pumps and two engine-driven gear pumps
Total pump capacity	180.3 l/min
Auxiliary flow	52.5 l/min
System relief pressure for auxiliary circuit 3	226 bar
System relief pressure for auxiliary circuit 2	235 bar

SLEW SYSTEM

Boom swing, left	80°
Boom swing, right	50°
Slew rate	9.4 RPM

FLUID CAPACITIES

Cooling system	11.2 l
Engine lubrication plus oil filter	9.2 l
Fuel reservoir	118 l
Hydraulic reservoir	148 l

ENVIRONMENTAL

Noise level LpA (EU Directive 2006/42/EC)	74 dB(A)
Noise level LWA (EU Directive 2000/14/EC)	97 dB(A)
Whole body vibration (ISO 2631-1)	0.54 ms ⁻²
Hand-arm vibration (ISO 5349-1) (L/R)	0.89 ms ⁻² / 0.67 ms ⁻²

STANDARD FEATURES

1920 mm dozer blade	Lockable storage compartment
2000 mm dipperstick	Horn
Boom and arm load holding valve	Work lights
Dozer blade safety valve	Retractable seat belt
Fully adjustable air conditioning	TOPS/ROPS cab ¹
Heated suspension seat with high back	Harness for rotating beacon
Consoles with forwards/backwards adjustable displacement	Overload warning device
Steering column with adjustable angle	Sun visor
Second auxiliary hydraulic line (rotation piping)	Two left and one right rear view mirrors
Fingertip auxiliary hydraulic control	Electric refueling pump
Control console locks	Auto idle
Hydraulic joystick controls	Warranty: 12 months, 2000 hours (whichever occurs first)
Two-speed travel	7" Deluxe display

¹ Tip Over Protective Structure (TOPS) – Meets requirements of ISO 12117.

WORKING RANGE

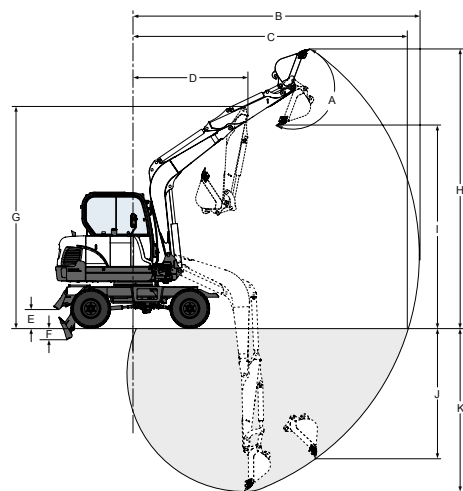

(A) 180°	(H) 5976 mm
(B) 6108 mm	(H*) 6170 mm
(C) 5988 mm	(I) 4324 mm
(C*) 6190 mm	(I*) 4510 mm
(D) 2448 mm	(J) 2805 mm
(D*) 2464 mm	(J*) 3115 mm
(E) 421 mm	(K) 3495 mm
(F) 202 mm	(K*) 3795 mm
(G) 4692 mm	
(G*) 4686 mm	

* with long dipperstick

DIMENSIONS

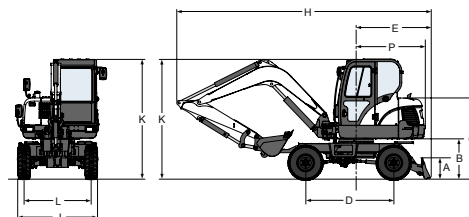

(A) 500 mm	(H) 6120 mm
(B) 980 mm	(J) 1850 mm
(C) 1935 mm	(K) 2950 mm
(D) 2100 mm	(L) 1600 mm
(E) 1678 mm	(P) 1650 mm

OPTIONS

- Long dipperstick
- Twin tyres with 2290 mm dozer blade
- Third auxiliary hydraulic line (clamshell piping)

Specifications and design are subject to change without notice. Pictures of Bobcat products may show other than standard equipment.



Bobcat®

www.bobcat.eu