



ATTACHMENTS

SALT AND SAND SPREADER



One Tough Animal[™]

SALT AND SAND SPREADER – SPECIFICATIONS

Main features

- Bob-Tach™ mounted.
- Self loading from a stockpile like a normal bucket.
- An agitator is located in the hopper to facilitate the flow of caked material.
- Can be adjusted to spread 180 degrees in front of the machine, up to 8.2 metres wide.

Applications

- Salt & sand spreading for winter maintenance.
- Seed and fertilizer spreading for lawn care.

	Item number	Compatible with loader
Spreader HS8	7157284	S130, S150, S160, S175, S185, S205, S220, S250, S300, S330, S630, S650, S770, S850, A300, A770, T140, T190, T250, T300, T320, T650, T770, T870

Weights and dimensions

	Operating weight (kg)	Shipping weight (kg)	Overall width (C) (mm)	Overall height (B) (mm)	Overall length (A) (mm)
Spreader HS8	176	176	1382	1039	815

Characteristics and performance

	Hopper capacity struck (m³)	Hopper capacity heaped (m³)	Motor
Spreader HS8	0.272	0.33	Hydr.

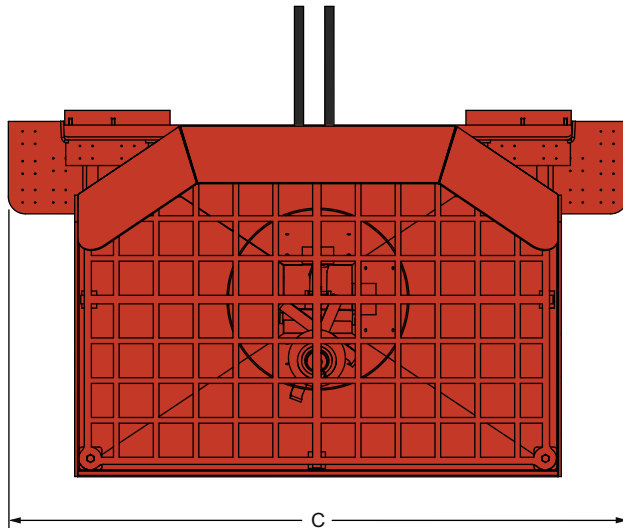
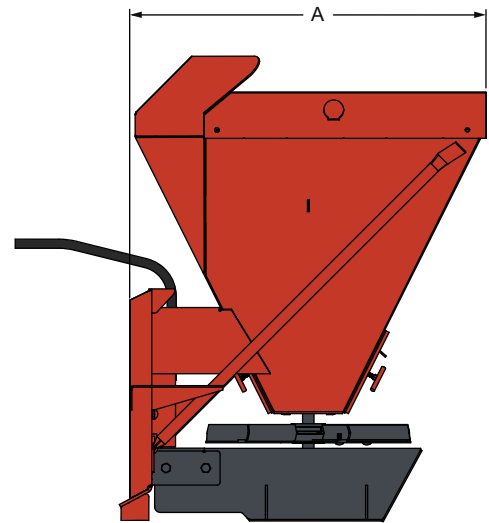
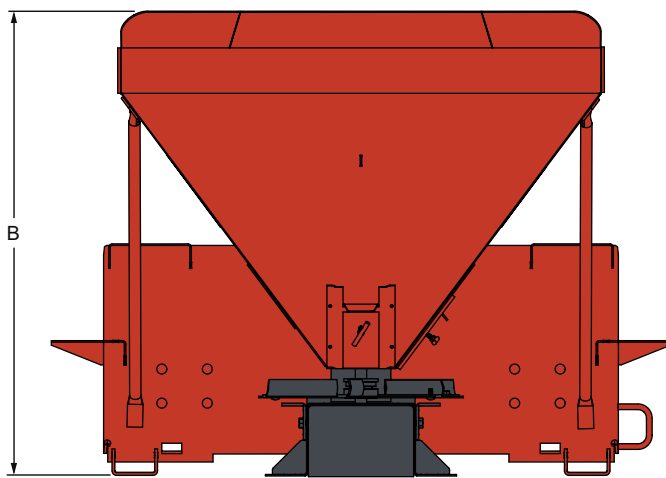

Specifications and design are subject to change without notice. Pictures of Bobcat products may show other than standard equipment.



www.bobcat.eu