

► Comfortable segregating

A segregator bucket is a perfect attachment for excavator usage. Screening and separating was not so easy and productive before. Every machine driver can install this tool on site and start working immediately.



This bucket range is maintenance friendly and very popular to demolition, road-construction and recycling companies. The segregator bucket is like an ordinary riddle-bucket.

Two individually framed bar gratings are powered by a hydraulic motor, via an eccentric shaft, creating a reciprocating motion causing the under size materials to exit the bucket through the alternating bar spaces.

► Applications:

- Topsoil cleaning
- Cleaning of contaminated soils
- Brick cleaning
- Back filling of cable and pipelines
- Recycling of rubble
- Excavation of graveyards
- Loading of concrete crushers
- Cleaning of construction area's

“By use on site, maximum profit is guaranteed!”

► Segregator bucket

► Rotar Cleaner

► Sorting /Demolition Grab

► Tyne Re-handling Grab

► Segregator bucket

► Scrap Shear

► Jawcrusher bucket

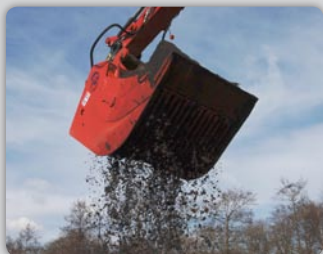

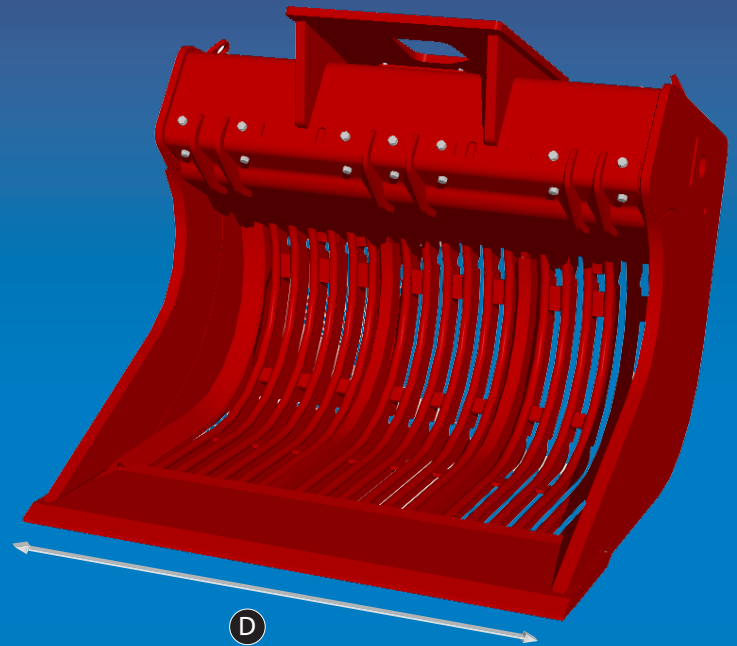
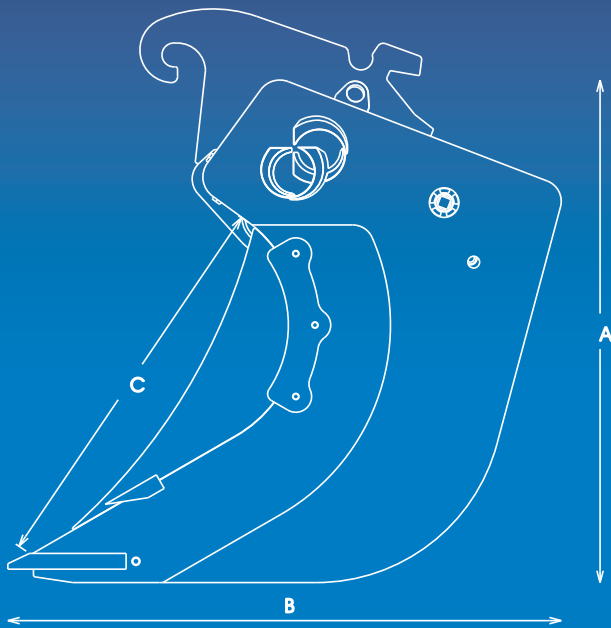

Type EVB	EVB 600 S	EVB 800 S	EVB 1200 S
Information			
WEIGHT (KG) EXCL. ADAPTER	1100	1475	1885
CAPACITY (L) CECE	600	800	1200
MACHINE WEIGHT (T)	13-18	16-25	21-35
Dimensions			
DIMENSION A (MM)	1275	1275	1275
DIMENSION B (MM)	1400	1400	1695
DIMENSION C (MM)	1000	1000	1140
DIMENSION D (MM)	1200	1560	1610
Hydraulic			
MAX. OPERATION PRESSURE MOTOR (BAR)	140	140	140
MAX. OIL-FLOW MOTOR (L/MIN.)	70-100*	70-100*	70-100*

* System is controlled by a flowcontrol-valve

Specifications may change without prior notice

Optional:
Teeth

Your Attachment Supplier