

## ▶ Productive segregating

A segregator bucket is a perfect attachment for all kind of separations. Screening and separating was not so easy and productive before. Every machine driver can install this tool on site and start working immediately. This bucket range is maintenance friendly and very popular to demolition, road-construction and recycling companies.

The segregator bucket is like an ordinary riddle-bucket.

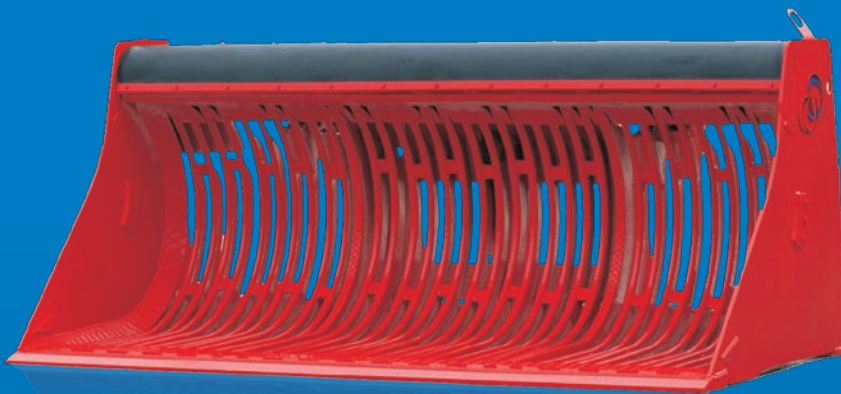

Two individually framed bar gratings are powered by a hydraulic motor, via an eccentric shaft, creating a reciprocating motion causing the under size materials to exit the bucket through the alternating bar spaces.

## ▶ Applications:

- Topsoil cleaning
- Cleaning of contaminated soils
- Brick cleaning
- Back filling of cable and pipelines
- Recycling of rubble
- Excavation of graveyards
- Loading of concrete crushers
- Cleaning of construction area's

“Such a popular attachment will turn into profit within a short while”

## ▶ Segregator bucket

### ▶ Rotar Cleaner

### ▶ Sorting/Demolition Grab

### ▶ Tyne Re-handling Grab

### ▶ Scrap Shear

### ▶ Jawcrusher bucket

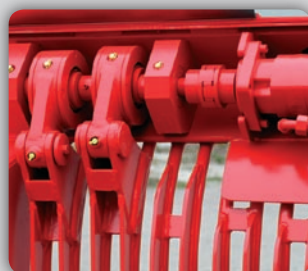

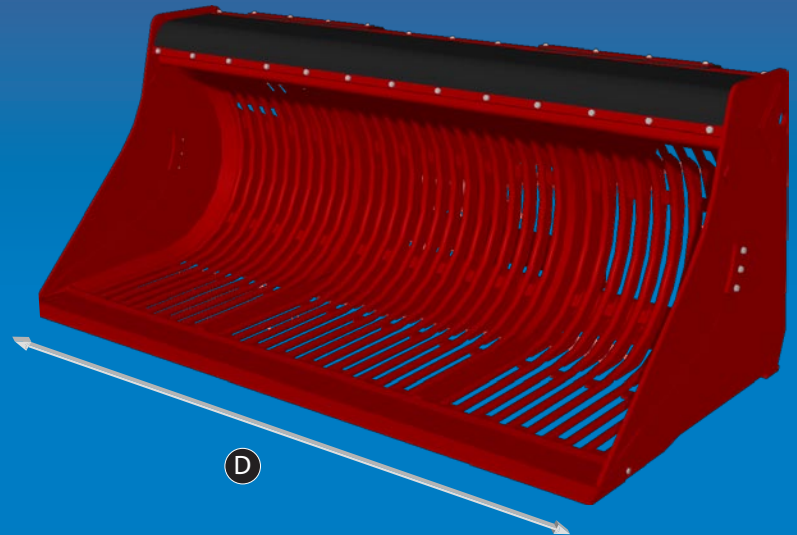
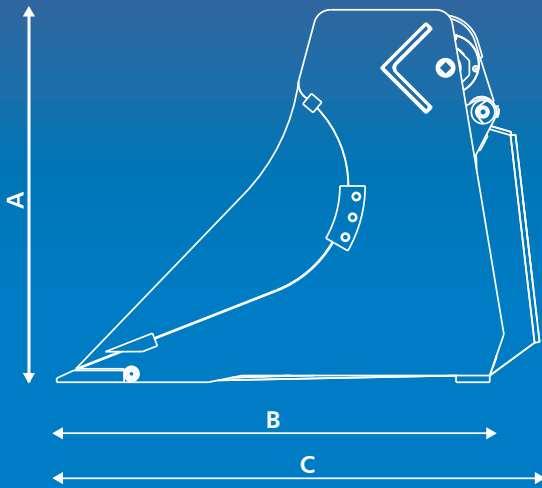

Type RVB	800 S	950 S	1500 L	2000 S	2300 I
<b>Information</b>					
WEIGHT (KG)	860	950	1500	1800	2260
CAPACITY (L) SAE 1: 2	1025	1155	1650	2050	2225
MACHINE WEIGHT (T)	4,5-7,5	6-9	7,5-10	10-12	12-15
<b>Dimensions</b>					
DIMENSION A (MM)	935	935	1105	1105	1105
DIMENSION B (MM)	950	950	1136	1286	1425
DIMENSION C (MM)	1112-1214	1112-1214	1490	1433	1697
DIMENSION D (MM)	2060	2320	2420	2650	2730
<b>Hydraulic</b>					
MAX. OIL-FLOW MOTOR (L/MIN.)	75	75	75	75	75
MAX. OPERATION PRESSURE MOTOR (BAR)	140	140	140	140	200

Specifications may change without prior notice

- System is controlled by a flowcontrol-valve

Optional:  
Teeth

*Your Attachment Supplier*