



Bobcat®

ATTACHMENTS

MIXING BUCKET



One Tough Animal™

MIXING BUCKET – SPECIFICATIONS

Main features

- Side discharge for MB200 and MB250 models.
- Dual discharge.
- Mix and dump functions are fingertip controlled.
- Mix while driving.
- No need for additional control kit.

Applications

- Construction
- Landscaping
- Renovation

	Item number	Compatible with loader	Compatible with telescopic
Mixing bucket MB200SD	7185474	S150, S160, S175, S185, S205, S220, S250, S300, S330, S630, S650, S770, A300, A770, T190, T250, T300, T320, T650, T770	T2550
Mixing bucket MB250SD for Bob-Tach	7185472	S175, S185, S205, S220, S250, S300, S330, S630, S650, S770, A300, A770, T190, T250, T300, T320, T650, T770	T2556, T2566, T3571, T3571L, T35120L, T35120SL, T40140, T40170

Weights and dimensions

	Operating weight (kg)	Shipping weight (kg)	Overall width (C) (mm)	Overall height (B) (mm)	Overall length (A) (mm)
Mixing bucket MB200SD	350	350	1347	896	732
Mixing bucket MB250SD for Bob-Tach	370	370	1563	859	807
Mixing bucket MB250SD for Quick-Tach	370	370	1495	859	867
Mixing bucket MB600 for Quick-Tach	670	670	1900	1070	1100

Characteristics and performance

	Capacity (l)	Flow range (l/min)
Mixing bucket MB200SD	200	45 – 60
Mixing bucket MB250SD for Bob-Tach	250	45 – 75
Mixing bucket MB250SD for Quick-Tach	250	45 – 75
Mixing bucket MB600 for Quick-Tach	600	90 – 110

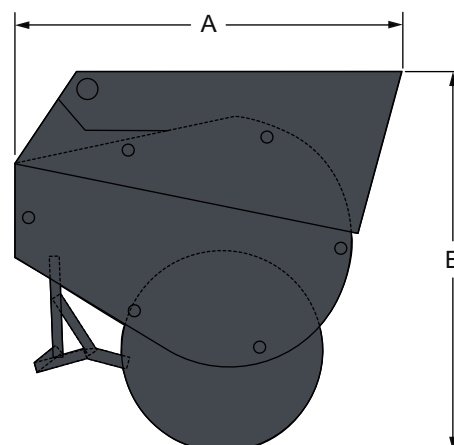

Specifications and design are subject to change without notice. Pictures of Bobcat products may show other than standard equipment.



Bobcat®

www.bobcat.eu